



# DEEBOT **X8 MAX** PRO OMNI

## Instruction Manual

## IMPORTANT SAFETY INSTRUCTIONS

### IMPORTANT SAFETY INSTRUCTIONS

When using an electrical Appliance, basic precautions should always be followed, including the following:

### **READ ALL INSTRUCTIONS BEFORE USING THIS APPLIANCE**

### **SAVE THESE INSTRUCTIONS**

1. This Appliance is not intended for use by persons (including children) with reduced physical, sensory or mental capabilities, or lack of experience and knowledge, unless they have been given supervision or instruction concerning use of the Appliance by a person responsible for their safety.
2. Children should be supervised to ensure that they do not play with the Appliance.
3. Clear the area to be cleaned. Remove power cords and small objects from the floor that could entangle the Appliance. Tuck rug fringe under the rug base, and lift items such as curtains and tablecloths off the floor.
4. If there is a drop off in the cleaning area due

to a step or stairs, you should operate the Appliance to ensure that it can detect the step without falling over the edge. It may become necessary to place a physical barrier at the edge to keep the unit from falling. Make sure the physical barrier is not a trip hazard.

5. Only use as described in this manual. Only use attachments recommended or sold by the manufacturer.
6. For INDOOR household use ONLY. Do not use the Appliance in outdoor, commercial, or industrial environments.
7. Do not use without dust bin and/or filters in place.
8. Do not operate the Appliance in an area where there are lit candles or fragile objects.
9. Keep hair, loose clothing, fingers, and all parts of body away from any openings and moving parts.
10. Do not operate the Appliance in a room where an infant or child is sleeping.
11. Do not use and store in extremely hot or cold environments (below  $-5^{\circ}\text{C}$  / $23^{\circ}\text{F}$  or above  $40^{\circ}\text{C}$  / $104^{\circ}\text{F}$ ). Please charge the robot in temperature above  $0^{\circ}\text{C}$  / $32^{\circ}\text{F}$  and below  $40^{\circ}\text{C}$  / $104^{\circ}\text{F}$ .
12. Do not use Appliance on wet surfaces or

- surfaces with standing water.
13. Do not allow the Appliance to pick up large objects like stones, large pieces of paper, or any item that may clog the Appliance.
  14. Do not use Appliance to pick up flammable or combustible materials such as gasoline, printer or copier toner, or use in areas where they may be present.
  15. Do not use Appliance to pick up anything that is burning or smoking, such as cigarettes, matches, hot ashes, or anything that could cause a fire.
  16. Do not put objects into the suction intake. Do not use if the suction intake is blocked. Keep the intake clear of dust, lint, hair, or anything that may reduce air flow.
  17. If the power cord is damaged, it must be replaced by the manufacturer or its service agent in order to avoid a hazard.
  18. Turn OFF the power switch before cleaning or maintaining the Appliance.
  19. The lithium battery type suitable for CH2497D is Max. 4 cells, max. nominal voltage DC 14.4V, rated capacity 5,800mAh. The battery must be removed and discarded according to local laws and regulations before disposal of the Appliance.
  20. Please dispose of used batteries according to local laws and regulations.
  21. Do not incinerate the Appliance even if it is severely damaged. The batteries can explode in a fire.
  22. The Appliance must be used in accordance with the directions in this Instruction Manual. Ecovacs Home Service Robotics cannot be held liable or responsible for any damages or injuries caused by improper use.
  23. The robot contains batteries that are only replaceable by skilled persons. To replace the robot's battery, please contact Customer Service.
  24. Please make sure your power supply source voltage matches the power voltage marked on the OMNI Station.
  25. Use only the original rechargeable battery and OMNI Station provided with the Appliance from the manufacturer. Non-rechargeable batteries are prohibited.
  26. Take care not to damage the power cord. Do not pull on or carry the Appliance or OMNI Station by the power cord, use the power cord as a handle, close a door on the power cord, or

- pull power cord around sharp edges or corners.  
Do not run Appliance over the power cord.  
Keep power cord away from hot surfaces.
27. Do not use the OMNI Station if it is damaged. The power supply is not to be repaired and not to be used any longer if it is damaged or defective.
  28. Do not use with a damaged power cord or receptacle. Do not use the Appliance or OMNI Station if it is not working properly, has been dropped, damaged, left outdoors, or come in contact with water. It must be repaired by the manufacturer or its service agent in order to avoid hazards.
  29. The plug must be removed from the receptacle before cleaning or maintaining the OMNI Station.
  30. Remove the Appliance from the OMNI Station, and turn OFF the power switch to the Appliance before removing the battery for disposal of the Appliance.
  31. When not using the OMNI Station for a long period of time, please unplug it.
  32. If the robot will not be used for a long time, power OFF the robot for storage and unplug

the OMNI Station.

33. **WARNING:** Add clean water into the clean tank only.
34. **WARNING:** For the purposes of recharging the battery, only use the detachable supply unit CH2497D provided with the Appliance.









To satisfy RF exposure requirements, a separation distance of 20 cm or more should be maintained between this device and persons during device operation.

To ensure compliance, operations at closer than this distance is not recommended. The antenna used for this transmitter must not be co-located in conjunction with any other antenna or transmitter.

### **Device Update**

Typically, some devices are updated bi-monthly, but not always so specific. Some devices, especially those that went on sale more than three years ago, will only be updated if a critical vulnerability is found and fixed.

To check the current software version and enable automatic updates, go to Settings > Robot Advanced Settings > About Your Robot > Update in the app. The current version is displayed there; tap Update to enter the page and select Automatic Update to enable it.

	Caution: hot surface
	Short-circuit-proof safety isolating transformer
	Switch mode power supply
	For indoor use only
	Direct current
	Alternating current
	Before charging, read the instructions.
	Polarity of the charging port
	Time-lag miniature fuse-link

The remote surveillance is for the absolute private use of non-public, private owned places for the pure self-protection and single control intended only. Please be aware of the local data protection based legal obligations in case of use. No surveillance of public places, especially with clandestine intent and/or on the part of the employer without justified reasons. Such not justified use is in the risk and responsibility of the user only.

## European Union Compliance Statement Information on Disposal for Users of Waste Electrical & Electronic Equipment



This symbol on the product or on its packaging indicates that used electrical and electronic products should not be mixed with unsorted municipal waste. For proper treatment, it is your responsibility to dispose of your waste equipment by arranging to return it to designated collection points. Disposing of this product correctly will help save valuable resources and prevent any potential negative effects on human health and the environment, which could otherwise arise from inappropriate waste handling.

To return your used device, please use the return and collection systems or contact the retailer where the product was purchased, which is free of charge, please contact your local authority for further details of your nearest designated collection point.

Penalties may be applicable for incorrect disposal of this waste, in accordance with your national legislation.

## Information on Disposal for Users of used batteries



This symbol means that batteries and accumulators, at their end-of-life, should not be mixed with unsorted municipal waste. Your participation is an important part of the effort to minimize the impact of batteries and accumulators on the environment and on human health. For proper recycling you can return this product or the batteries or accumulators it contains to your supplier or to a designated collection point, which is free of charge.

Disposing of this product correctly will help save valuable resources and prevent any potential negative effects on human health and the environment, which could otherwise arise from inappropriate waste handling.

Penalties may be applicable for incorrect disposal of this waste, in accordance with your national legislation. there are separate collection systems for used batteries and accumulators.

Please, dispose of batteries and accumulators correctly at your local community waste collection/recycling center.

## Restriction of the use of certain hazardous substances (RoHS) Directive

Ecovacs Home Service Robotics Co., Ltd. hereby declares the whole product including parts (cables, cords, and so on) meets the requirements of RoHS Directive 2011/65/EU and amendment Commission Delegated Directive (EU) 2015/863 on the restriction of the use of certain hazardous substances in electrical and electronic equipment ("RoHS recast" or "RoHS 2.0").

## Radio Equipment Directive

Ecovacs Home Service Robotics Co., Ltd. hereby declares that the product listed in this section comply with the essential requirements and other relevant provisions of the Radio Equipment Directive 2014/53/EU.

## Europe Authorised Representative:



ECOVACS Europe GmbH  
Holzstrasse 2 | D-40221 Düsseldorf | Germany

Ecovacs Home Service Robotics Co., Ltd. hereby declares that the product comply with the essential requirements and other relevant provisions of the RoHS Directive 2011/65/EU and amendment Commission Delegated Directive (EU) 2015/863, the Radio Equipment Directive 2014/53/EU. The declaration of conformity can be viewed at the following address:

<https://www.ecovacs.com/global/compliance>.

# PACKAGE CONTENTS

## 1 Package Contents

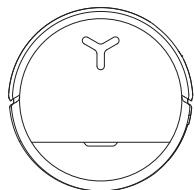

Robot

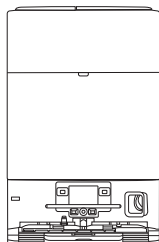

OMNI Station

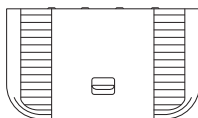

Base

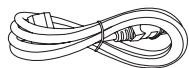

Power Cord

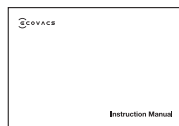

Instruction Manual

### Note:

\*Figures and illustrations are for reference only and may differ from actual product appearance. Product design and specifications are subject to changes without notice.

## 2 Product Diagram

### 1. Robot Front View

Button on the robot

Short Press: Start/Pause

Long Press for 3s: Return to charge

Double tap: Roller Mop Release/Retract

(Robot not in the station)

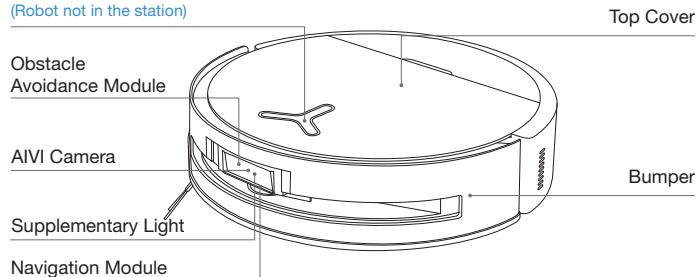

### 2. Robot Bottom View

Anti-drop Sensors

Side Brush

Carpet Detection Sensor

Brush Release Button

Drip Tray

Replaceable Roller Mop

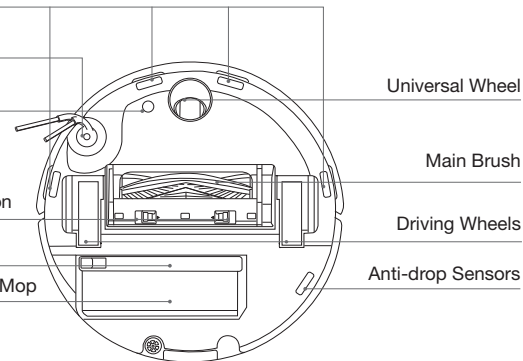

### 3. Internal View (Under the Cover)

#### RESET Button

**Network Setup:** Press the RESET Button and follow the voice prompt to set up the network.

**Restore to default settings:** Long press the RESET Button for 5 seconds. After you hear the voice prompt, the startup music will be played and the robot will be restored to default settings.

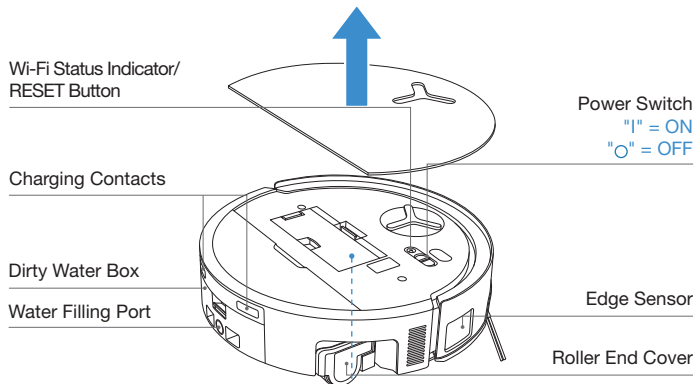

### 4. Dust Bin

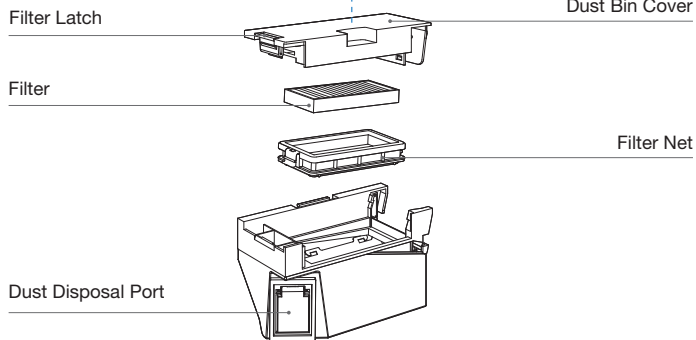

### 5. OMNI Station Front View

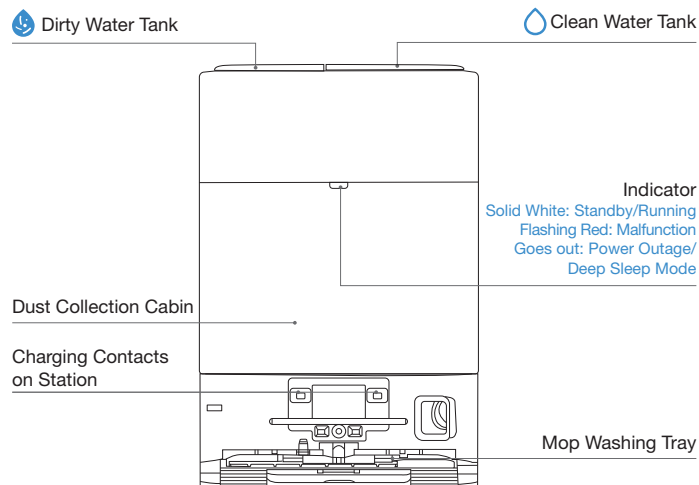

#### Note:

- If the Indicator flashes red, go to the ECOVACS HOME App for details about the malfunction.
- If the robot cannot charge, wipe the corresponding charging contacts on the OMNI Station with a dry cloth.

### 6. Dust Bag

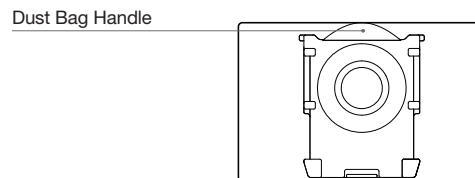

## 7. OMNI Station Back View

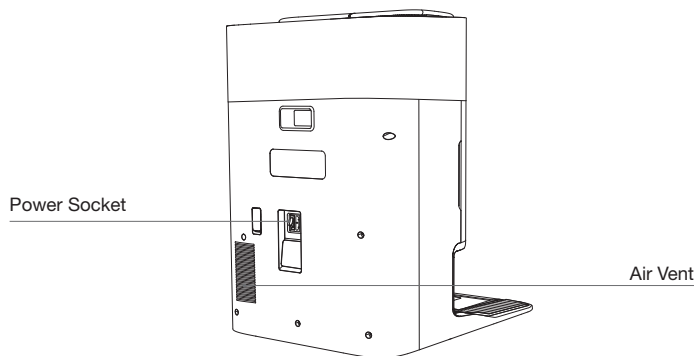

## 8. Sensors

Product Diagram	Functional Description
Navigation Module	Laser Ranging is applied to measure the distance between the robot and surrounding objects based on the time difference of reflection, allowing the module to map against the objects around while the robot is moving. The detection range is 10 m.
Obstacle Avoidance Module	With Infrared Ranging-detection and the concept of similar triangles, the sensor emits infrared rays and receives the light from the objects ahead to calculate the distance between the object and the robot. When the sensor detects an object nearby, the robot will automatically take a turn to avoid bumping into the object. The detection range is 0.3 m.
Anti-drop Sensors	Infrared Ranging is applied by the sensor at the bottom of the robot to measure the height between the bottom of the robot and the ground. When at the top of the stairs, for example, with a height above 55mm on white-colored ground or a height above 30mm on black-colored ground, the robot will stop advancing, fulfilling the feature of Anti-drop.
Carpet Detection Sensor	The ultrasound probe can emit ultrasonic waves with a frequency of 300KHZ. The energy of the ultrasonic waves can be absorbed by carpets. If the reflected energy is below the threshold, the robot will recognize the presence of a carpet. According to ECOVACS lab tests, currently, over 50 types of carpets available on the market can be identified.
Anti-collision Sensor	When the transmitted signal is blocked by an object, the signal receiver will not be able to receive it. With this principle, the robot will avoid obstacles when encountering them.
Edge Sensor	With ToF distance measurement, the robot can detect the distance between itself and objects on its right side. When there is a wall or obstacle on the right side, the robot will perform edge cleaning to avoid missing spots or collisions.
AIVI Camera	Use AI cameras to collect images of the surrounding environment. *Realize video recording. Through interaction with MIC, remote video call can be realized(For some models).
Microphone	Human voices cause vibrations in the diaphragm of the microphone through air. As a result, the microphone utilizes the collection and algorithms of sound models to achieve sound recording and voice control of the robot to complete specific tasks. The effective wake-up distance is 5 m.

# NOTES BEFORE CLEANING

## 1 Warnings



### Prepare the Area

Tidy up the area to be cleaned by putting furniture, such as chairs, in their proper place. Put away low-lying items, such as weight scales, before using the robot.



Put away objects including cables, cloths and slippers, etc. on the floor to improve the cleaning efficiency.

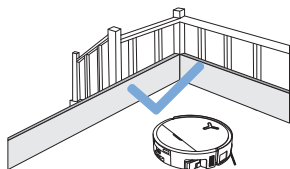

### Set up Protective Barriers

It may be necessary to place a physical barrier at the edge of a steep drop to stop the robot from falling over the edge.



Before using the product on a rug or carpet with tasseled edges, please fold the rug and tuck the tassels under the rug.

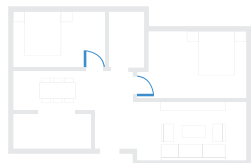

### Keep Doors Open

During the first use, make sure each room door is open to help the robot fully explore your house.



Please do not stand in tight spaces such as doorways and hallways, and make sure not to block the robot's path when it's identifying areas.

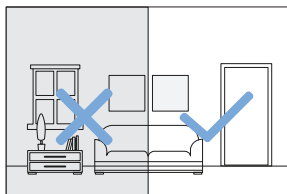

### Provide Sufficient Lighting

The robot can avoid shoes, sockets and cords etc., and make sure all areas to be cleaned are well illuminated, which can improve obstacle avoidance.



Ensure the clarity of the robot's vision and avoid scratching or smudging the AI camera lens with fingerprints or oily stains. Use a clean, soft cloth to wipe the camera, instead of cleaning agents, detergents, or sprays.

## 2 Quick Start

Before using, please remove all protective materials from the robot and OMNI Station.

### 1. Installation

The sound of "click" indicates proper installation.

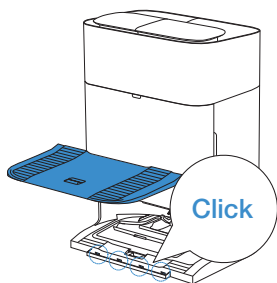

### 2. Power Cord Connection and Station Placement

Place the station against a wall on a level, hard ground. Ensure there are no objects within 0.05 m on either side and 0.8 m in front of it.

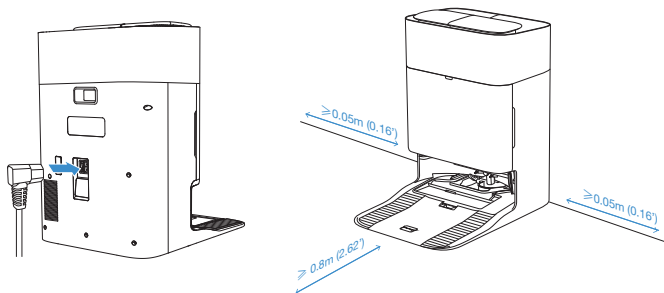

#### Note:

- If there are reflective objects such as mirrors and skirting lines near the OMNI Station, the bottom 14 cm of them should be covered.
- Do not place the OMNI Station under direct sunlight.
- Place the station in a location with a strong Wi-Fi signal.

## 3 Power ON and Charge the Robot

Turn on the power switch under the robot's cover ('I' indicates power on, and 'O' indicates power off). Place the robot in front of the station, ensuring the station is connected to a power supply. Use the ECOVACS HOME App or voice command to recall the robot to start charging at the OMNI station, or long press the robot button  for 3 seconds, and it will return to the station to charge.

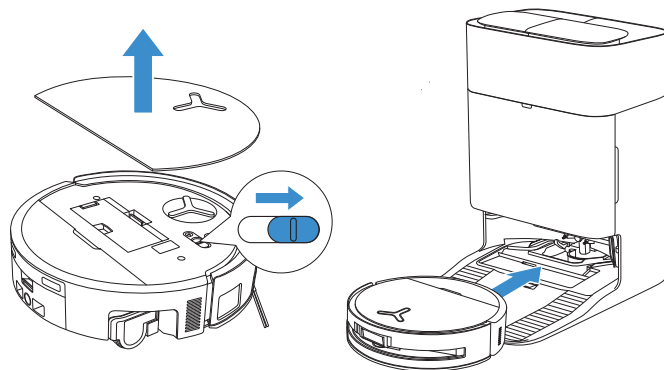

#### Note:

- The robot can't be charged when the power is turned off.
- After the robot finishes its cleaning task, it is recommended not to power it off but to keep it charging, to better prepare for the next cleaning session.
- It is recommended that the robot start cleaning from the OMNI Station. Do not move the OMNI Station while cleaning.

## 4 Download the ECOVACS HOME App

Download the ECOVACS HOME App to enjoy more features.

You may scan the QR Code on the robot to download the App.

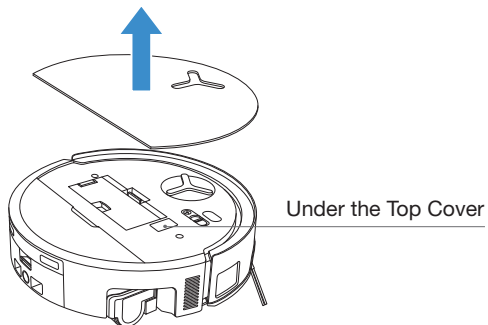

Or search for the ECOVACS HOME in your mobile App store to download the App.



**Note:** Follow the guide of the App to register, log in, and connect the product with the App.

## 5 Connect Robot with App

**Via Bluetooth:** Turn on the robot and mobile phone Bluetooth. Allow the App to obtain mobile phone Bluetooth permission. Tap to scan the QR Code on the robot or tap  or **Add** in the App to find the nearby robot.

**Via Wi-Fi:** You can also choose to connect the robot with the App through other methods according to the prompts on the App's page.

**Note:** Please connect via Bluetooth for a better experience.

### Wi-Fi Network Requirements:

- You are using a 2.4GHz or 2.4/5 GHz mixed network.
- Your router supports 802.11b/g/n and IPv4 protocol.
- Do not use a VPN (Virtual Private Network) or Proxy Server.
- Do not use a hidden network.
- WPA and WPA2 using TKIP, PSK, AES/CCMP encryption.
- WEP EAP (Enterprise Authentication Protocol) is not supported.
- Use Wi-Fi channels 1-11 in North America and channels 1-13 outside North America (refer to local regulatory agency).
- If you are using a network extender/repeater, the network name (SSID) and password are the same as your primary network.
- Please enable the WPA2 on your router.

### Wi-Fi Indicator Light

	White Flashing Slow	Disconnected to Wi-Fi
	White Flashing Fast	Connecting
	Solid White	Connected to Wi-Fi

Please note that to access smart features such as remote startup, voice interaction, 2D/3D map display and control settings, and personalized cleaning (features may vary depending on the product), you'll need to download and use the ECOVACS HOME App, which receives constant updates. You must agree to our Privacy Policy and User Agreement before we can process some of your basic and necessary information and enable you to operate the product via the ECOVACS HOME App. Without your agreement, some of the aforementioned smart features cannot be accessed through the ECOVACS HOME App. Nevertheless, you can still use the product's basic functions for manual operation.

## 6 Add Cleaning Solution (sold separately)

1. Take off the dust container cover, pull out the cleaning solution unit, and place it on a level, hard surface.

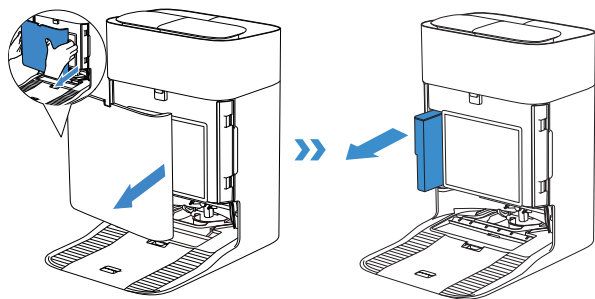

2. Unlid the cleaning solution unit and fill it with ECOVACS cleaning solution. Put the lid on and the unit back to the station.

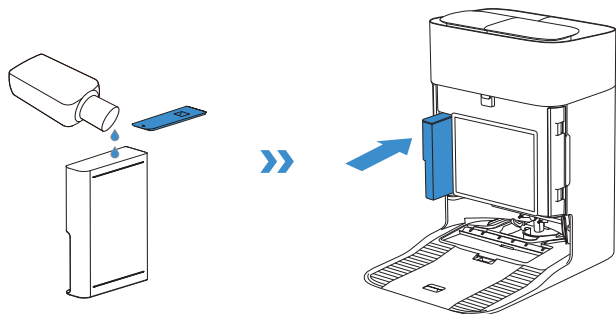

**Note:** Cleaning solution is pumped automatically from the cleaning solution unit. Do not add cleaning solution to the water tanks.

3. Insert the top latch of the dust container cover into the slot, and then press downward to ensure a proper seal.

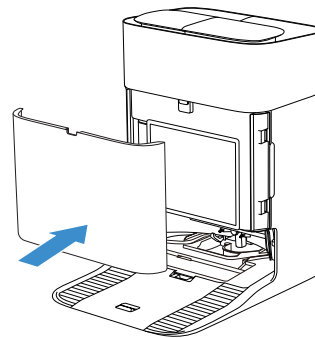

### Note:

- Please use ECOVACS cleaning solution in case of malfunction.
- Please make sure that no foreign objects fall into the cleaning solution unit.

## 7 Start Cleaning

### 1. Start Mapping

Order the robot to start mapping by the ECOVACS HOME App or voice control.

When creating a map for the first time, please follow the robot to help eliminate some minor issues. For example, the robot may get stuck under the furniture. Please refer to the following solutions:

1. Raise the low sitting furniture if possible;
2. Cover the bottom of the furniture;
3. Set up virtual boundary via the App.

When mapping, the robot will explore the house environment automatically. The exploration path may be different from cleaning path.

### 2. Start Cleaning

- The robot's water tank is automatically refilled through the OMNI Station. Manual refilling is not needed.
- When mopping, the robot will recognize floor types and is able to lift mops automatically when encountering carpets. Please do not use the robot on shaggy rugs or carpets with fibres longer than 10 mm. It is recommended to fold up the shaggy rugs with fibres longer than 10 mm during the cleaning process, or go to Map > Carpet Cleaning Strategy in the ECOVACS HOME App to set the shaggy carpeted area as a No-Entry Zone.

Before cleaning for the first time, please make sure the robot is in the OMNI Station and fully charged. Tap  button on the robot to start cleaning. You can also use the ECOVACS HOME App or voice control to start cleaning.

### 3. Pause

Tap  on the robot to pause while it is working. You can also use the ECOVACS HOME App or voice control to pause the robot.

### 4. Wake up

After pausing for a while, all indicator lights on the robot will go out. To wake up the robot, short press .

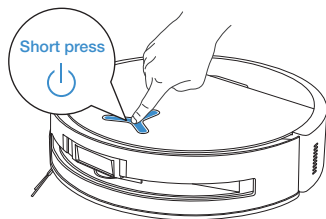

### 5. Return to OMNI Station

Use the ECOVACS HOME App or voice to recall DEEBOT to enter the Station to charge it up. Long press the button for 3 s on the DEEBOT can also recall it.

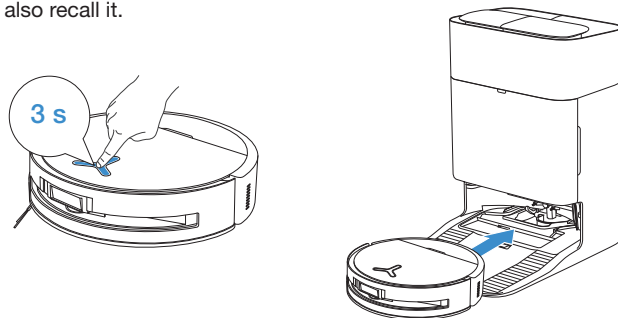

### 6. Deep Sleep Mode

The robot will enter deep sleep mode to protect the battery if it stays outside the OMNI Station for about 10h. Please switch OFF and ON to wake up the robot.

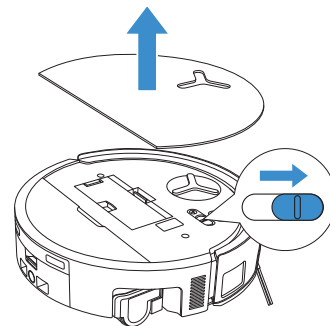

# Regular Maintenance

## ① Maintenance Frequency

To ensure optimal performance, maintain and replace parts at the following frequencies:

Part	Maintenance Frequency	Replacement Frequency
Replaceable Roller Mop	Every week	Every 1-2 months
Drip Tray	Every week	/
Dirty Water Box	Every week	/
Dust Bag	/	Every 2-3 months
Side Brush	/	Every 3-6 months
Main Brush	Every week	Every 6-12 months
Filter	Every week	Every 3-6 months
Edge Sensor Universal Wheel Anti-drop Sensors Bumper Charging Contacts on Robot Charging Contacts on OMNI Station Navigation Module Obstacle Avoidance Module AIVI Camera	Approx. every month	/
Clean Water Tank	Every 3 months	/
Dirty Water Tank	Every month	/
Dust Container Inside	Every month	/
Body and Bottom of Station	Every month	/
Mop Washing Tray	Every 5 months	/

**Note:** Explore more accessories at ECOVACS HOME App or at <https://www.ecovacs.com>.

## ② Dust Bin

1. Remove the dust bin and then open its cover to empty the bin.

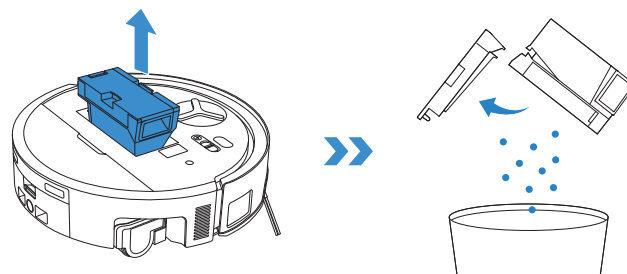

2. Open the dust bin cover to remove the filter and filter net.

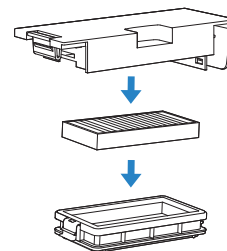

3. You can rinse the components. Afterwards, give them a good shake to remove leftover water droplets.

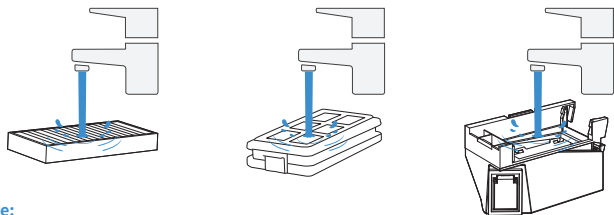

**Note:**

- Please rinse the filter with water.
- Do not use fingers or brushes to clean the filter.

4. Air-dry the dust bin and filter.

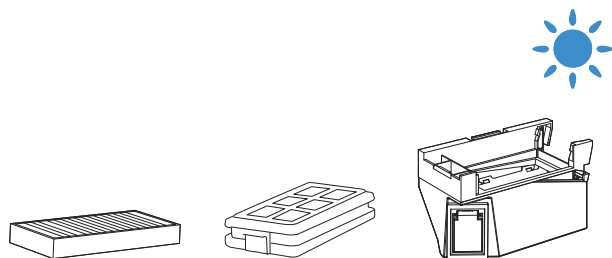

**Note:** Completely dry the filter before use.

### 3 Maintain Main Brush and Side Brush

Clean the Main Brush.

1. Remove the cover on the main brush.

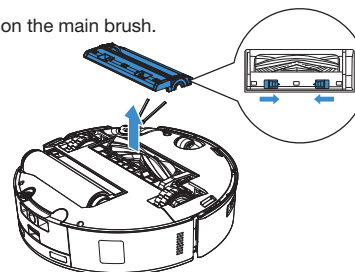

2. Remove and clean the main brush.

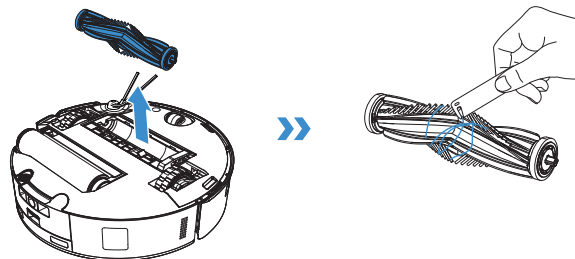

3. Remove, clean and dry the brush comb.

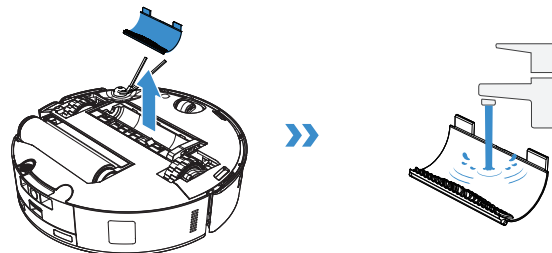

4. Install the brush comb, main brush and the cover.

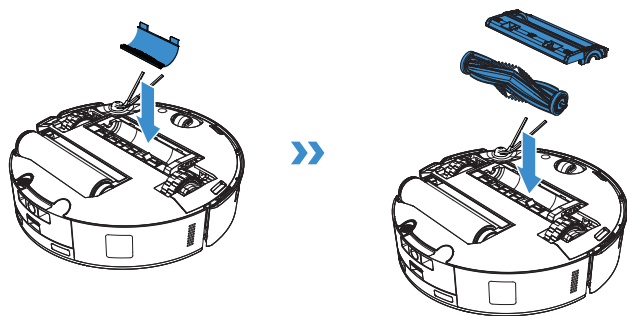

### Clean the Side Brush.

Remove the side brush using a screwdriver and clean it.

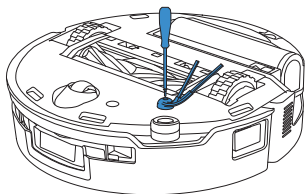

**Note:** Explore more accessories in the ECOVACS HOME App or at <https://www.ecovacs.com>.

## 4 Roller Mop, Drip Tray and Dirty Water Box

### Clean the Roller Mop.

1. Double click  button to release roller mop component.

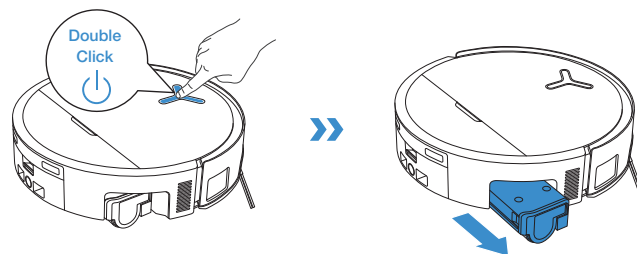

**Note:** Please avoid excessive force when handling the roller; it should be removed and placed with care.

2. Press the unlock button to remove the roller.

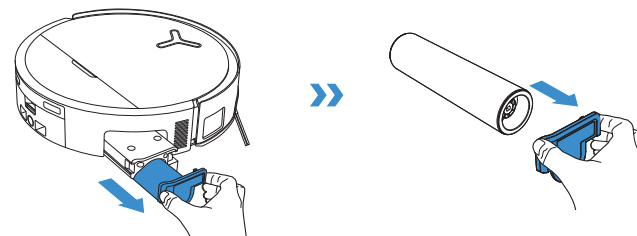

3. Clean the roller mop.

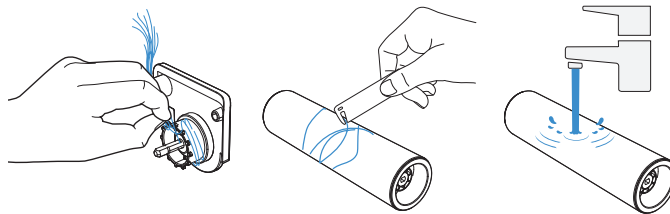

4. Clean inside the roller.

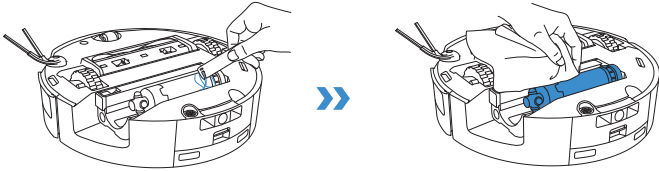

**Note:** Do not wash the robot with water.

5. Push roller mop into roller end cover and double click  button to retract.

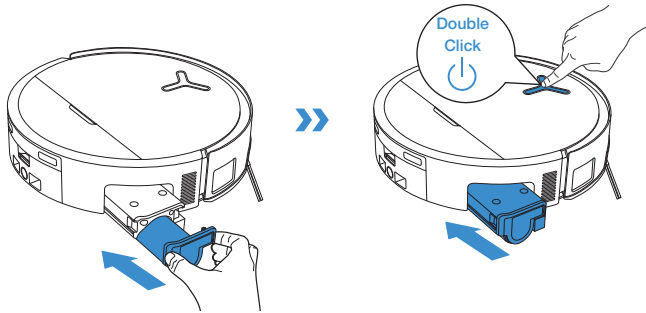

## Clean Drip Tray

1. Remove drip tray.

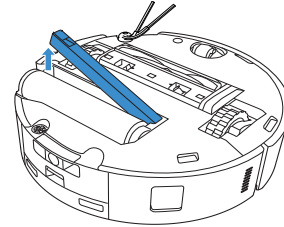

**Note:** A small amount of residual water may leak out when flipping the robot if it's not in drying mode.

2. Remove and clean drip tray components.

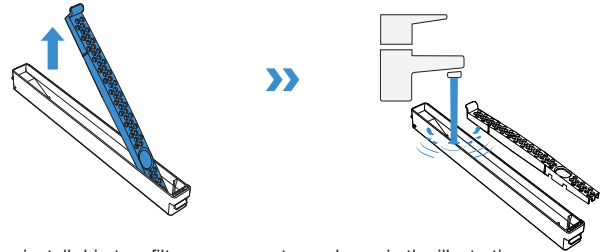

3. Please install drip tray filter components as shown in the illustration.

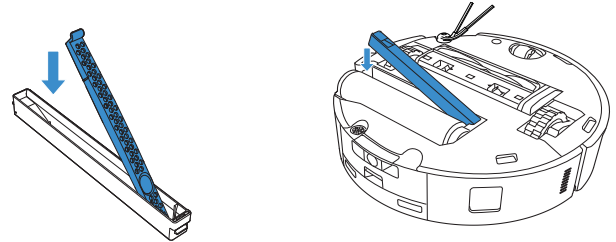

## Clean Dirty Water Box

1. Remove dirty water box and the filter.

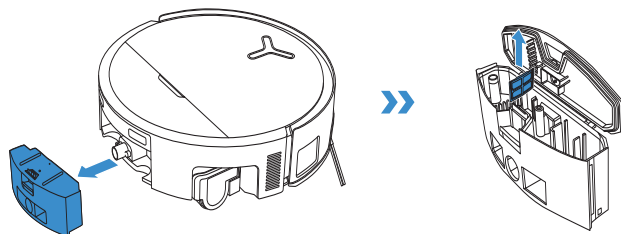

2. Clean the filter, box and sewage outlet.

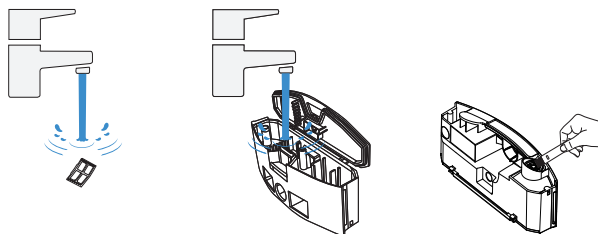

3. Reinstall the filter, press securely and then reattach the dirty water box cover.

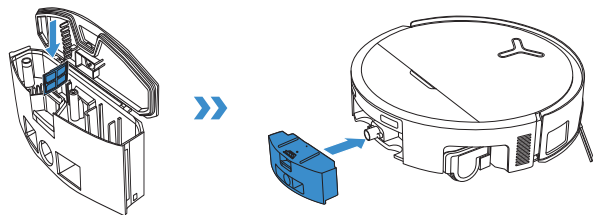

## 5 Other Components

### Clean the Obstacle Avoidance Module Lens

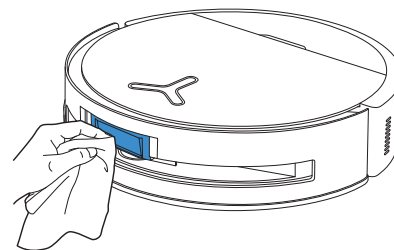

### Clean the Bumper

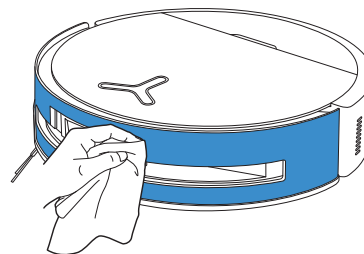

**Note:** Use a dry cloth when cleaning the Anti-drop sensors and bumper to prevent water damage.

## Clean Navigation Module

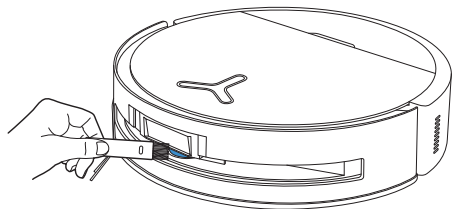

**Note:** Rotate the Module lens to the front and clean it gently with a brush when cleaning.

## Clean Charging Contacts

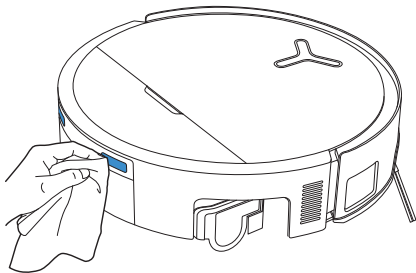

**Note:** Wipe the contacts with a dry cloth. Avoid using wet cloth to prevent water damage.

## Clean the Edge Sensor

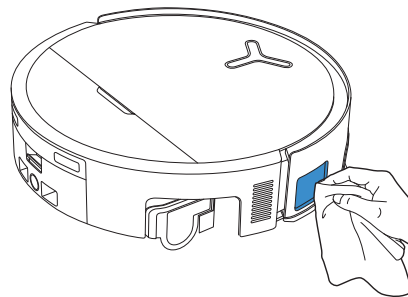

## Clean the Anti-drop Sensors

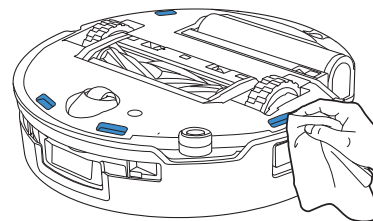

## Clean the Universal Wheel

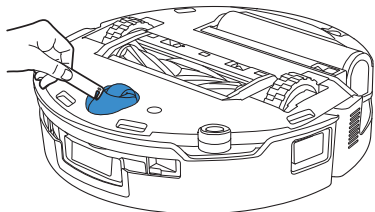

## Clean the Driving Wheels

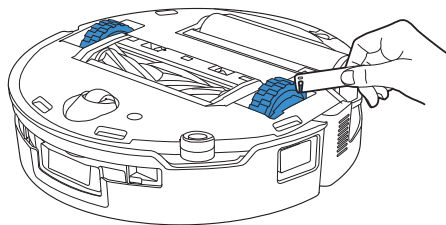

**Note:** Use dry cloth when cleaning the charging contacts to prevent water damage.

## 6 Mop Washing Tray and Station Base

1. Remove and clean mop washing tray and station base.

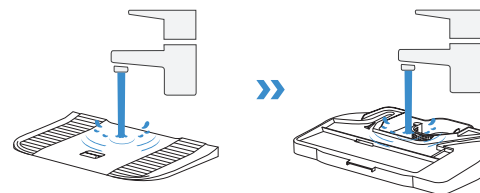
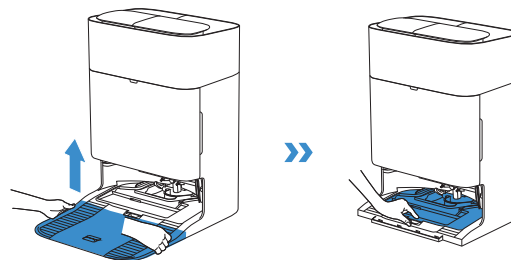

2. Install the tray and base.

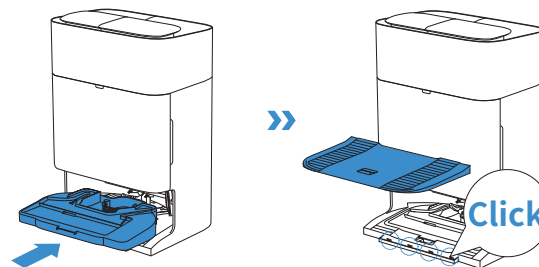

**Note:** Please install the tray and base properly to prevent malfunction.

## 7 Dust bag

1. Remove dust container cover.

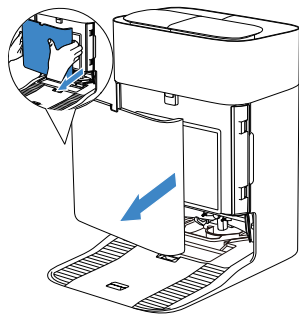

2. Remove the disposable dust bag in the direction of the arrow and discard it.

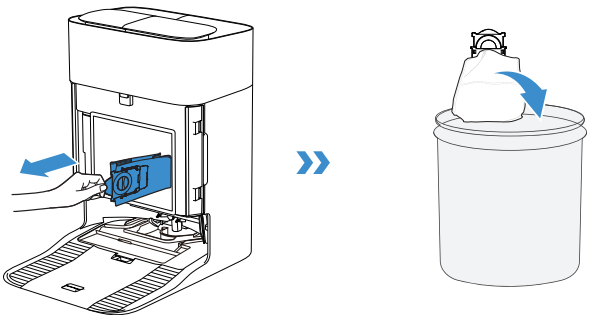

3. Clean the dust container with a dry cloth, install a new dust bin, and confirm proper installation with a secure click sound.

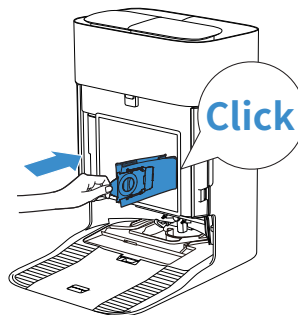

4. Return dust bag and press the cover firmly to secure it in position.

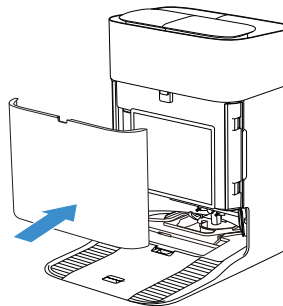

**Note:** Hold the Handle to lift out the dust bag, which can effectively prevent dust leakage.

## 8 Storage

Please fully charge and switch OFF the robot before storage. Please recharge it every 1.5 months to prevent the battery from over-discharging.

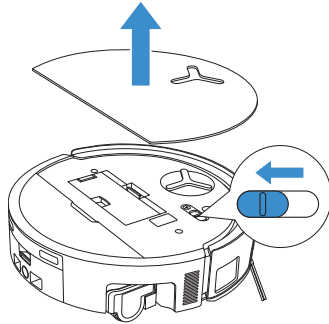

**!** Please note that the robot cannot charge when powered OFF.

### Note:

- After the robot finishes its cleaning task, it is recommended not to power it off but to keep it charging, to better prepare for the next cleaning session.
- If the battery is over-discharged or not used for a long time, the robot may not be charged. Please contact ECOVACS for help. Do not disassemble battery by yourself.
- If you do not use the product for a long time, keep the dirty water box, water tanks empty and the mop dry.

# TROUBLESHOOTING

For the following possible issue, refer to the corresponding solutions.

No.	Malfunction	Possible Cause	Solution
1	The robot is not able to connect to the ECOVACS HOME App.	Incorrect Wi-Fi username or password entered.	Enter the correct Wi-Fi username and password.
		The robot is not within range of your home Wi-Fi signal.	Make sure the robot is within range of your home Wi-Fi signal. Try to stay as close to the router as possible.
		The robot is not in the configuration state.	Press the Reset Button to connect the robot to your phone by Bluetooth. If failed, please press the Reset Button +  , and to connect via the ECOVACS HOME App.
		There is no home Wi-Fi on the Wi-Fi list.	Check if the Wi-Fi name contains special characters. Please do not use special characters like ! @#& ¥%/\. Do not use a 5 Ghz network.
		Incorrect App installed.	Please download and install the ECOVACS HOME App.
2	Unable to create the furniture map in the App.	Move the robot when cleaning might cause the map to be lost.	During cleaning, do not move the robot.
		Auto cleaning is not finished.	Make sure the robot automatically return to the OMNI Station after cleaning.
3	The side brush drops out of place during use.	The side brush is not properly installed.	When installing the side brush with a screwdriver, ensure the screws are tightened.
4	No signal found. Unable to return to the station.	The station is incorrectly placed.	Please place the station correctly according to the instructions in the <a href="#">[Quick Start]</a> section.
		The station is out of power or moved.	Check whether the OMNI Station is connected to the power supply. Do not move the OMNI Station.
		The robot does not start cleaning from the OMNI Station.	It is recommended that the robot starts cleaning from the OMNI Station.
		The docking route is blocked. For example, the door is closed to the room where the station is placed.	Keep the charging route clear.

No.	Malfunction	Possible Cause	Solution
5	The robot returns to the station before it has finished cleaning.	The room is so large that the robot needs to return to recharge.	Please enable auto resume. For more details, please follow the App instructions.
		In highly complex home layouts, cleaning efficiency may decrease, possibly resulting in incomplete cleaning.	Simplify your home layout.
6	The robot is unable to charge.	The robot is not switched ON.	Switch ON the robot.
		The robot's charging contacts are not connected to the OMNI Station's charging contacts.	Make sure that the robot's charging contacts have connected to the station's charging contacts and 🔌 flashes. Check whether the robot's and OMNI Station's charging contacts are dirty. Please clean these parts according to the instructions in the [Regular Maintenance] section.
		The OMNI Station is not connected to the power supply.	Make sure the OMNI Station is connected to power supply.
		Base has not been installed in place.	Refer to the [Quick Start] section for correct installation.
7	The robot is very loud during cleaning.	The main brush/side brush is tangled, or the dust bin/filter is blocked.	It is recommended to clean the main brush, side brush, dust bin, filter, etc. regularly.
		The robot is in strong mode.	Switch to standard mode.
8	The robot gets stuck while working and stops.	The robot is tangled with objects on the floor (electrical wires, curtains, carpet fringing, etc.).	The robot will try various ways to free itself. If its attempts fail, manually remove the obstacles and restart.
		The robot might be stuck under furniture with an entrance of similar height.	Please raise the furniture, set a physical barrier, or set a virtual boundary via the ECOVACS HOME App.
		The robot is stuck in a narrow area.	Tidy up your home, set a physical barrier, or set a virtual boundary via the ECOVACS HOME App.

No.	Malfunction	Possible Cause	Solution
9	During cleaning, the robot may encounter issues like a disorderly route, biased movement, repeated cleaning over the same spots, and missing small areas. (If there is a large area that has not been cleaned temporarily, the robot will automatically clean the missed area. Sometimes the robot will re-enter a cleaned room, which may not be repeated cleaning, but the robot finds any missed area.)	Objects such as wires and slippers placed on the ground block the robot.	Before cleaning, please tidy up scattered wires, slippers, and other objects on the ground as possibly can. If there is any area missed during cleaning, the robot will correct it automatically. Please refrain from interfering (such as moving the robot or blocking its route).
		The driving wheels may slip on the ground when the robot climbs steps, thresholds, and door bars, which can affect its judgement of the entire home environment.	It is recommended to close the door of the affected area and clean it separately. After cleaning, the robot will return to its starting location.
		On freshly waxed or polished floors, as well as smooth tiles, there may be less friction between the driving wheels and the floor.	Please wait for the wax to dry before cleaning.
		Due to variations in home layouts, some areas cannot be entered by the robot.	Tidy up your home to ensure that the robot can enter the areas to be cleaned.
10	Delay in remote control.	The Wi-Fi signal is poor, causing the video loading to be slow.	Use the robot in areas with good Wi-Fi signal.
11	After returning to the OMNI station, the robot does not empty its dust bin.	The auto-empty function has not been turned on in the ECOVACS HOME App.	Turn on the auto-empty function in the ECOVACS HOME App.
		Manually moving the robot back to the station may not trigger the auto-empty function.	It is recommended to allow The robot return to the OMNI Station on its own. Please do not manually move it.
		In do not disturb mode, the robot will not empty the dust after returning back to the OMNI Station.	Turn off do not disturb in the ECOVACS HOME App or manually start dust-emptying.
		The station detects a decrease in empty efficiency.	Replace the dust bag according to the [Regular Maintenance] section and close the dust collection cabin. If the dust bag is not full when prompted by the App, you can put it back again.
		If the above possible causes have been ruled out, components of the station may be abnormal.	Please contact customer service for assistance.

No.	Malfunction	Possible Cause	Solution
12	Auto-empty failed.	The station detects a decrease in empty efficiency.	Replace the dust bag according to the [Regular Maintenance] section and close the dust collection cabin. If the dust bag is not full when prompted by the App, you can put it back again.
		The outlet of the dust bin is blocked by foreign objects.	Remove the dust bin and clear the foreign objects on the outlet.
13	The inner side of the dust collection cabin is dirty.	Fine particles pass through the dust bag and accumulate on the inner side of the dust collection cabin.	Clean the inner side of the dust collection cabin.
		The dust bag is broken.	Check and replace the dust bag.
		The dust bag is not properly installed.	Please install the dust bag properly.
		The dust container cover is not closed.	Please check if the dust container cover is closed properly.
14	Dust leakage occurs while the robot is working	The outlet of the dust bin is blocked by foreign objects.	Remove the dust bin and clear the foreign objects on the outlet.
15	The roller mop does not rotate.	The roller mop is not correctly installed.	Install the roller mop properly according to the 【REGULAR MAINTENANCE】 section.
		The roller mop is blocked by foreign objects.	Clean and install roller mop properly according to the 【REGULAR MAINTENANCE】 section.
16	The driving wheel is stuck.	wheel is entangled or stuck due to foreign objects.	Rotate and press the driving wheel to check for any wrapping or obstruction by foreign objects. If any foreign objects are found, please clean them promptly. If this issue persists, please contact customer service for assistance.

No.	Malfunction	Possible Cause	Solution
17	The mop washing tray is full of water and can't be emptied. A voice prompt reports mop washing tray malfunction.	The dirty water tank is not properly installed.	Tap down on the dirty water tank to ensure it is properly installed.
		The sealing plugs in the dirty water tank are not installed properly.	Make sure that the two sealing plugs are properly installed.
		Mop washing tray is not properly installed.	Please check and make sure that the mop washing tray is properly installed.
		Mop washing tray base gets dirty.	Ensure that there is no foreign object in the suction port of the mop washing tray.
		Check if the floating ball gets stuck when there is no water in the mop washing tray base.	Take out the mop washing tray to put the floating ball back in place.
		The OMNI Station cannot drain water normally.	Put the robot into the station and double tap  , if the issue persists, please contact our customer service for help.
		The suction port of the mop washing tray is blocked by foreign objects.	Ensure that there is no foreign object in the suction port of the mop washing tray.
		The voice alert persists after all the above solutions are tried.	Power off and on the station. If this issue persists, please contact customer service for assistance.
18	Dirty water box malfunction.	The drainage outlet of dirty water box gets blocked and the draining pole can't work normally.	Remove and empty the dirty water box, and then rinse it and reinstall. If this issue persists, please contact customer service for assistance.

**Please contact our customer service for assistance if the problem persists despite the recommended solutions.**

## TECHNICAL SPECIFICATIONS

Model	DEX61-P		
Rated Input	20 V === 2 A	Charging Time	about 4.0 h
Station Model	CH2497D		
Rated Input	220-240 V ~ 50-60 Hz	Rated Output	20 V === 2 A
Rated Input Current (Charging)	0.5 A	Power (Emptying)	650 W
Power (Hot Water Washing Mop)	1650 W		
Frequency Bands	2400-2483.5 MHz		
Networked Standby Power	Less than 2.00 W		

Output power of the wireless module is less than 100 mW.

Note: Technical and design specifications may be changed for continuous product improvement.

Explore more accessories at <https://www.ecovacs.com>.

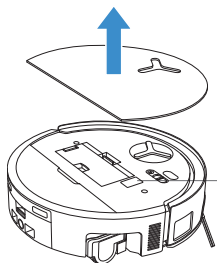

Please use the mobile camera to scan the QR code and obtain the user guide.

Ecovacs Home Service Robotics Co., Ltd.  
No.518 Songwei Road, Wusongjiang Industry Park, Guoxiang Street,  
Wuzhong District, Suzhou, Jiangsu, China.

451-2498-0648